

SMARTFLOW®

SWAP® VALVE

Quickly Purge Cooling Water using Shop Air

U.S. Patent No.
6,471,503



Brass Body with
Stainless Disc



Reinforced Molded
Body with Stainless Disc

Available in two material choices:

1 and 2-inch sizes in
Brass with Stainless
Steel Disc

Most Economical:
Reinforced Molded Body,
1-inch size with Glass-
Filled Nylon Outer Plates
and Stainless Steel Disc

General Description

The Smartflow **SWAP Valve** supplies cooling water to the mold during processing. Secondly, it supplies air to purge the water from the mold, cooling lines, Supply and Return manifolds before tool change. It also provides a manual vent to release built-up air pressure within the cooling water loop after purging.

A check valve should be installed in the return line downstream from the Return manifold to prevent backflow to the mold.

Tubing may be connected to the manual vent-drain port so after the purge cycle any residual water can be released into a container or drain.

An optional spring-loaded, locking pin is available for molders who require two-hand operation. This prevents accidental valve handle movement.

Benefits

- **Implements SMED** by dramatically reducing tool change time.
- **Identifies Supply Lines** by noting which manifold is connected to the SWAP Valve.
- **Full Port Design** provides maximum cooling water flow with minimum pressure drop.
- **Prevents Slip Hazard** by keeping shop floors dry.
- **Prepares Injection Mold** for preventive maintenance and storage.
- **Optional Positive Locking Pin** prevents accidental valve handle movement.

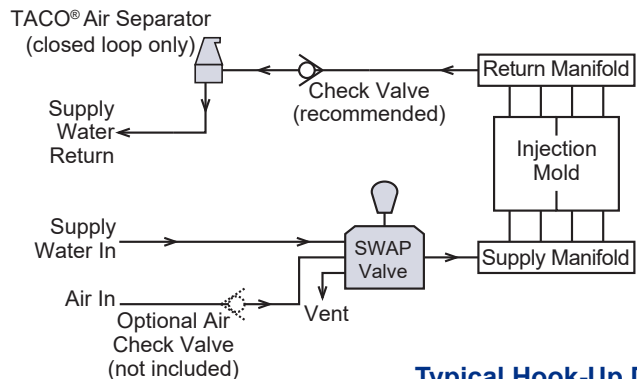

Typical Hook-Up Diagram

Application

The SWAP valve is well-suited for cooling water Supply lines up to 2-inch NPT. It is permissible to adapt 3/4", 1-1/4" and 1-1/2" line sizes providing adequate cooling water flow can be achieved.

Typical mounting is on press or safety door frame. Mounting on any suitable surface, such as a platen, mold or manifold stand is acceptable.

For Normal Processing	Select WATER. Cooling Water is available to the Supply manifold. Purge Air is blocked.
to Evacuate Cooling Water	Select PURGE. Purge Air is available to the Supply manifold. Cooling Water is blocked
To Bleed Trapped Pressure and Drain Residual Water	Select VENT Press Manual Vent-Drain Valve. Purge Air is blocked. Cooling Water is blocked.

Installation of an air separator in the return line of a closed loop cooling system is recommended. See the Typical Hook-Up Diagram (above) for location.

*Design and specifications are
subject to change without notice.*

**burger &
brown**
engineering, inc.

4500 E 142nd Street
Grandview, MO 64030 USA
Tel: 816-878-6675
www.smartflow-usa.com



SWAP® VALVE

Purge Cooling Water using Shop Air

Molded Body, Stainless Disc (1" only)

Specifications

Maximum Pressure 150psi (10.3bar)
 Maximum Operating Temperature.....250°F (121°C)
 Normal Working Air Pressure.....80 to 100psi
 Pressure Drop across Purge Valve 1psi at 50gpm

Wetted Parts

BodyGlass-Filled Nylon
 Valve Disc Stainless Steel
 O-Rings..... EPDM
 Check Valve (recommended) Brass



Model Numbers with Check Valve

Model	Thread Size	Locking Pin	Weight
SPV8-A-M	1"NPT	no	2.5kg 5.5lbs
SPV8-L-M	1"NPT	yes	
SPV8B-A-M	1"BSPP	no	
SPV8B-L-M	1"BSPP	yes	

Model Numbers without Check Valve

Model	Thread Size	Locking Pin	Weight
SPV8-A-MN	1"NPT	no	2.1kg 4.7lbs
SPV8-L-MN	1"NPT	yes	
SPV8B-A-MN	1"BSPP	no	
SPV8B-L-MN	1"BSPP	yes	

Brass Body, Stainless Disc (1" or 2" models)

Specifications

Maximum Pressure 150psi (10.3bar)
 Maximum Operating Temperature.....250°F (121°C)
 Normal Working Air Pressure.....80 to 100psi
 Pressure Drop across Purge Valve 1psi at 50gpm

Wetted Parts

Body Brass
 Valve Disc Stainless Steel
 O-Rings..... EPDM
 Check Valve (recommended) Brass



Model Numbers with Check Valve

Model	Thread Size	Locking Pin	Weight
SPV8-A-B	1"NPT	no	5.4kg 12lbs
SPV8-L-B	1"NPT	yes	
SPV8B-A-B	1"BSPP	no	
SPV8B-L-B	1"BSPP	yes	
SPV16-A-B	2"NPT	no	14.5kg 32lbs
SPV16-L-B	2"NPT	yes	
SPV16B-A-B	2"BSPP	no	
SPV16B-L-B	2"BSPP	yes	

Model Numbers without Check Valve

Model	Thread Size	Locking Pin	Weight
SPV8-A-BN	1"NPT	no	5kg 11.1lbs
SPV8-L-BN	1"NPT	yes	
SPV8B-A-BN	1"BSPP	no	
SPV8B-L-BN	1"BSPP	yes	
SPV16-A-BN	2"NPT	no	13.4kg 29.6lbs
SPV16-L-BN	2"NPT	yes	
SPV16B-A-BN	2"BSPP	no	
SPV16B-L-BN	2"BSPP	yes	



SWAP[®] VALVE

Purge Cooling Water using Shop Air

All Models, Maximum Dimensions

Dimension	SPV8	SPV16
A	299mm/11.75"	395mm/15.5"
B	221mm/8.7"	297mm/11.7"
C	119mm/4.7"	173mm/6.8"
D	130mm/5.1"	160mm/6.3"

Accessories, All Models

Part Number	Description
PVCV-100	Brass Check Valve 1"NPT
PVCV-200	Brass Check Valve 2"NPT
PVCV-100B	Brass Check Valve 1"BSPP
PVCV-200B	Brass Check Valve 2"BSPP
PVCV-3	Air Check Valve 3/8"NPT

TACO[®] 4900 Series Air Separators

TACO 4900 Series Air Separators are designed for the complete elimination of air from closed loop water circulating systems. Small air bubbles and micro-bubbles adhere to surfaces on pall rings in the water path and join together to form larger air bubbles. The combined bubbles travel up through the water and into the conical air chamber to be released by the vent at the top.

Recommended for use with **SMARTFLOW SWAP Valve** in a closed loop cooling water system.

Specifications

Connection Sizes	1" & 2"NPT(F)
Housing Material	Brass
Pall Ring Material	Stainless Steel
Venting Unit Materials	Stainless Steel EPDM, Viton, Engineered Plastics
Operating Pressure Max	150psi (10bar)
Operating Temperature Max	240°F (115°C)
Operating Temperature Min	25°F (-4°C)
Media	Water or Water/Glycol
Max. Velocity	5ft/sec



Dimensions & Weights

Model Number	Connection Size	A	B	C	Weight	
					kg	lbs.
49-100	1"	5-1/2" 139mm	6-3/4" 171mm	4-3/8" 111mm	2	4.5
49-200	2"	6-5/8" 169mm	8-7/16" 214mm	5-3/16" 13mm	2.7	6.0

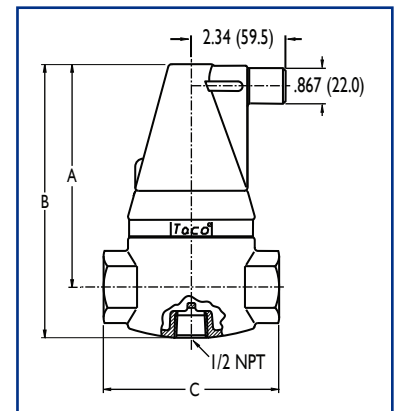

TACO[®] is a registered trademark of Taco, Inc.

SMARTFLOW® *SMED Friendly Product Guide*

Three ways to implement SMED (Single Minute Exchange of Die) in Injection Molding Operations.

Manufacturing Engineers strive to reduce setup times and maximize machine run times, increasing profits. Setup times are reduced by converting internal operations (done when the press is idle) to external operations (done while the press is running). Additionally, setup times are reduced by using the proper tools to decrease the time required by internal operations.

A select group of **SMARTFLOW** products help manufacturing engineers achieve their goals:

- Duoflow® Manifolds
- SWAP® Valves
- FasTie® Quick Ejector Tie-In

1 Duoflow® Manifolds convert an internal operation to an external operation by connecting all cooling water lines to a mold-mounted cooling water manifold. Molds are stored with manifolds installed and all cooling lines connected. Water hook-up time is reduced to seconds by using one connection for Supply Water and one connection for Return Water using quick disconnect fittings on the ends of the manifolds.



2 SWAP® Valves reduce time required for cooling line evacuation between mold changes to seconds instead of minutes while keeping shop floors clean. SWAP valves use shop air to evacuate fluid from cooling lines with a single handle motion.

Three valve positions: Water, Purge and Vent provide needed functions to allow molds to be changed faster than clearing water lines individually. The reverse handle motion opens the cooling water supply to return to normal processing.



3 FasTie® Quick Ejector Tie-In slashes knockout connection time to seconds with quick couplers and studs. FasTie couplers reside in the press ejector plate. FasTie pull studs are fastened to each mold in storage. When a mold change is performed, ejector tie-in is literally a snap. Visit our YouTube channel to view animations of different FasTie applications: <https://www.youtube.com/user/burgerandbrowneng>



burger & brown engineering, inc.

4500 E 142nd Street ♦ Grandview, MO 64030 USA

Tel: 816-878-6675

www.smartflow-usa.com

